

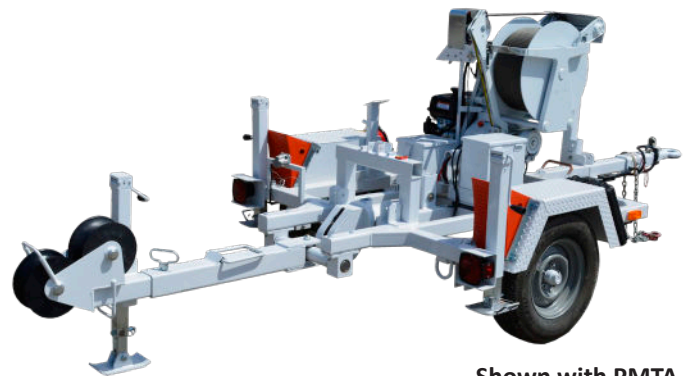

UD-50 Underground Puller

5,000-lb. Pulling Capacity

- 1 Compact and rugged for remote jobsites
- 2 Rope entry at a fixed point for better anchorage
- 3 Even, constant pulling force
- 4 Equipped with a tension dynamometer and adjustable overload cut-off
- 5 Available with pad-mount transformer adapter or with A-frame adapter



Shown with PMTA

Specifications

Engine	8-10 Hp
Fuel Capacity	1.25 gal
Pulling Rope	3/8 in. dia. steel cable
Reel Capacity	1,500 ft. (3/8 in. dia.)
Skid Frame Construction	Steel tubing, continuous-weld
Wheel Configurations & Tires	14 x 5.5 drop center; ST205-75R 14BC
Brakes (Trailer)	Electric, standard
Tongue Jack	Screw type w/ wheel
Bumper (SS/CS) Jacks	Screw type w/ shoe
Width (Overall, Approx.)	63 in.
Length (Overall, Approx.)	91 in.
Height (Approx.)	48 in.
Weight (Approx.)	1,200 lb.
Frame Construction (Trailer)	Steel tubing

Options

- Air adapter kits
- Underground blocks available
- Brakes, trailer hydraulic surge



Shown with A-frame Adapter