

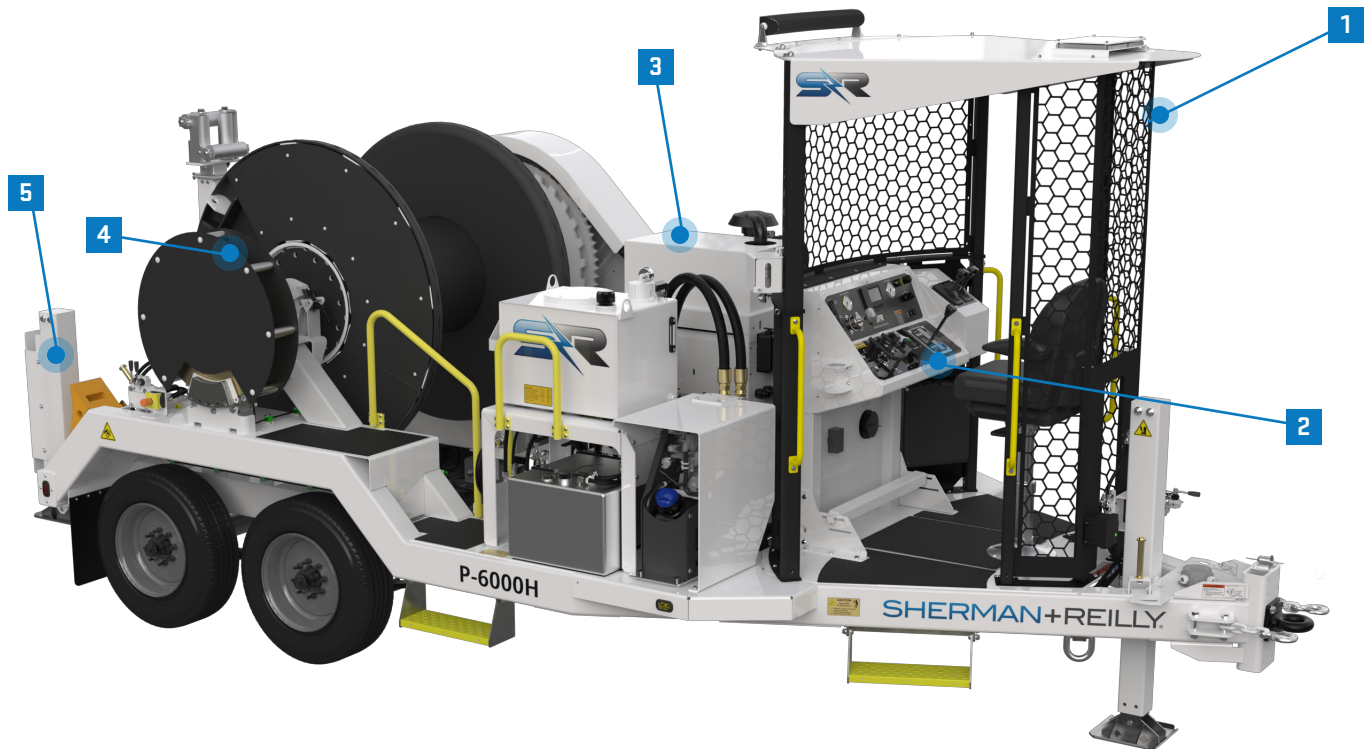

SHERMAN+REILLY®

# P-6000H HERITAGE PULLER

6,000 LB. PULLING CAPACITY



- 1 Safe-Zone® enclosure with Ocu-View™.
- 2 All stringing operations controlled from the safety of the Safe-Zone® enclosure.
- 3 Chain drive; single hydraulic motor, Penta-drive coupling system with remote engagement.
- 4 Helicopter-ready payout brake.
- 5 Manual jacks standard on bumper (2) and tongue (1). Hydraulic jacks option available.

## FEATURES

- Capable of pulling 6,000 lb. on a 62 in. diameter reel.
- Maximum line speed: pulling 6 mph.
- Drum capacity:  
Up to 15,500 ft. of 3/4 in. PE-12 or  
25,000 ft. of 1/2 in. Ultrex.
- Ratchet Pawl failsafe brake.

# P-6000H HERITAGE PULLER

6,000 LB. PULLING CAPACITY

Sherman-Reilly.com

## SPECIFICATIONS

|  |   |
|--|---|
| <b>Maximum Pulling Capacity</b>        | 6,000 lb.<br>(rated at 30 in. from drum center)   |
| <b>Minimum Tensioning Capacity</b>     | 1,250 lb. at top of drum and<br>3,500 lb. at core   |
| <b>Maximum Line Speed</b>              | Pulling: 6 mph<br>Tensioning: 30 rpm  |
| <b>Mechanical Payout Brake</b>         | 27.75 in. Bronze Disc, Helicopter-ready   |
| <b>Reconductoring Reel Size</b>        | 72 in. diameter / 45 in. width  |
| <b>Maximum Reel Weight</b>             | Dynamic over the road 6,400 lb.<br>Static jacks extended 11,000 lb.                           |
| <b>Drum Dimensions</b>                 | Core diameter: 24 in.<br>Usable width: 36 in.<br>Flange diameter: 62 in.                      |
| <b>Drum Capacity</b>                   | Up to 15,500 ft. of 3/4 in. PE-12 or<br>25,000 ft. of 1/2 in. Ultrex                          |
| <b>Drive System</b>                    | Chain drive: Single hydraulic motor,<br>Penta-drive Coupling System with<br>remote engagement |
| <b>Drive System Engine</b>             | Turbocharged, Tier-4 Final Diesel, 116<br>Hp, water-cooled Kubota®                            |
| <b>Fuel Capacity</b>                   | 30 gallons  |
| <b>Hydraulic Fluid</b>                 | ISO Grade 32  |
| <b>Hydraulic Reservoir</b>             | 25 gallon (32 usable gallons)   |
| <b>Hydraulic Fluid Filtration</b>      | 10 microns, return filter   |
| <b>Levelwind</b>                       | Hydraulically driven, operator Steady-<br>Rest™ controlled directional change                 |
| <b>Operator's Safety Enclosure</b>     | Open-air Safe-Zone® enclosure   |
| <b>Frame Construction</b>              | Steel tubing, steel plate, continuous<br>weld   |
| <b>Length (Overall, Nom.)</b>          | 20 ft. 6 in.  |
| <b>Width (Overall, Nom.)</b>           | 8 ft. 6 in.   |
| <b>Height (Overall, Nom.)</b>          | 9 ft. 4 in.   |
| <b>Weight (without rope)</b>           | 13,410 lb. without rope<br>15,765 lb. with drum & rope  |
| <b>GVWR</b>                            | 20,500 lb.  |
| <b>Axle Configuration / Suspension</b> | Tandem / Leaf-spring  |
| <b>Wheel Configuration &amp; Tires</b> | Single 235/75R 17.5 LJR   |
| <b>Brakes (Trailer)</b>                | Electric, with breakaway switch & visual<br>indicator for battery charge state.               |
| <b>Towing Attachment</b>               | 3 in. pintle eye, with two safety chains<br>& hooks   |
| <b>Tie Downs</b>                       | (4) 1 in. diameter steel D-rings  |
| <b>Bumper (SS/CS) Jacks</b>            | Single Speed Drop, Pin, and Crank   |
| <b>Tongue Jack</b>                     | Two Speed Drop, Pin, and Crank  |
| <b>Battery / Electrical System</b>     | (2) 12V/810 CCA/Group 27  |
| <b>Lights / Navigation</b>             | US DOT, LED, 12 VDC   |

|                          |              |
|--------------------------|--------------|
| <b>Grounding (2)</b>     | Grade 5H     |
| <b>Wheel Chocks</b>      | Standard (2) |
| <b>Fire Extinguisher</b> | ABC          |
| <b>Color</b>             | S+R White    |

## OPTIONS

|                                     |
|-------------------------------------|
| Hydraulic Jacks                     |
| Light bar with 12V accessory option |
| Air axle                            |
| Tongue extension                    |
| Solar battery charger               |
| Galvanized finish available         |
| 72 in. X 45 in. RCR reel            |



Streetside of P-6000H Heritage Puller

**EXPERIENCE THE  
DIFFERENCE**

**CONTACT OUR TEAM  
FOR A PRODUCT DEMO**

**(423) 756-5300 or  
sales@sherman-reilly.com**